

Spin S

GEN2



KEY BENEFITS

- Integrates into any urban space.
- Tool-free access from the top.
- Durability and sturdiness: IP66 + IK09.
- Die Cast aluminium (Cu<0.1%).
- Energy Efficient:
GEN2: 152 lm/W
GENA: 161 lm/W
- Up to 21 photometric distributions
- Smart Ready: Designed to house both indoor and outdoor communications nodes
- Future Proof: Zhaga-compliant
- Life span L90B10 100,000h (Ta) 25°C
- Night Friendly: ULR Arrêté du 27 décembre 2018
- Optional pre- or post-installation shielding for these luminaires.
- New PLUG&PLAY connector.
- 5 years warranty



DESCRIPTION

The new generation Spin is characterised by a renewed design more elegant and aesthetic. It features a simple design with a balanced silhouette, offering a harmony between the circular shape of the body and the straight lines of the bracket.

New PLUG&PLAY connector and its tool-free opening system allow for quick and easy installation and maintenance.

Spin family is certified with IDA mark, awarded by the International Dark Sky Association, which certifies that we comply with their approval programme to provide light that protects the environment and dark skies.

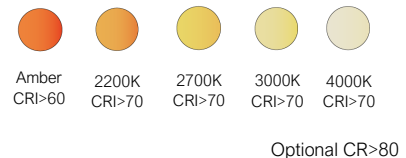

	GEN2: 618lm - 7.811lm GENA: 762lm - 8.203lm		6,7 Kg
	GEN2: 152 lm/W GENA: 161 lm/W		-40°C - +50°C
	Tool-free access to control gear		0,00% - 0,08% FHS/ULR

STANDARDS / CERTIFICATES

- CE
- RoHS
- UNE-EN 60598-1
- UNE-EN 60598-2-3 or 60598-2-5
- UNE-EN 62471:2009
- UNE-EN 60598
- UNE-EN 61000-3-2
- UNE-EN 61000-3-3
- UNE-EN 55015
- UNE-EN 61547
- UNE-EN 62031
- UNE-EN 61347-2-13
- UNE-EN 62384
- UNE-EN 13032-4
- UNE-EN ISO 9227 NSS: 2017 (1,000 h)

220 - 240 V / 100 V - 277 V
50-60 Hz
L90B10 100,000 h
Ta 25°C

Distributor: EPK elektro s.r.o.
info@carandini.cz - www.carandini.cz

PHOTOMETRIC DISTRIBUTIONS

It has the 21 photometric distributions used for the environments in which this type of luminaire is installed, allows it to adapt to all needs:

GEN1

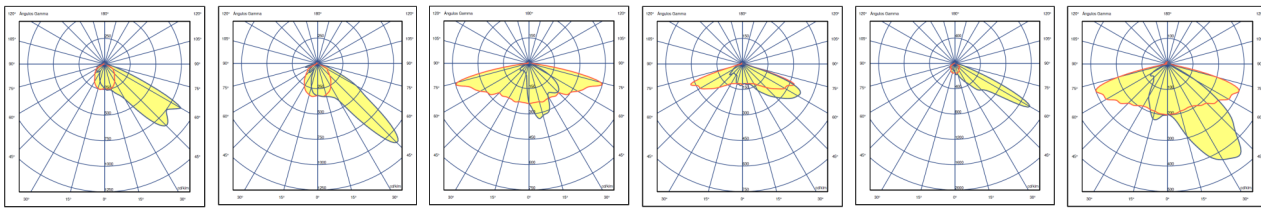

ACA1 ACM1 ALM1 AMA1 AMA2 AME2

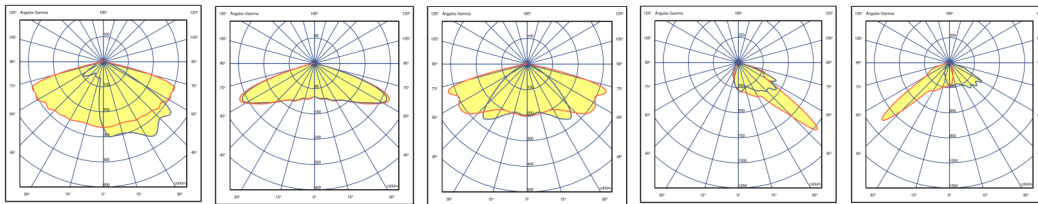

AMM1 SMA1 SME1 PCE1 PCE2

GENA

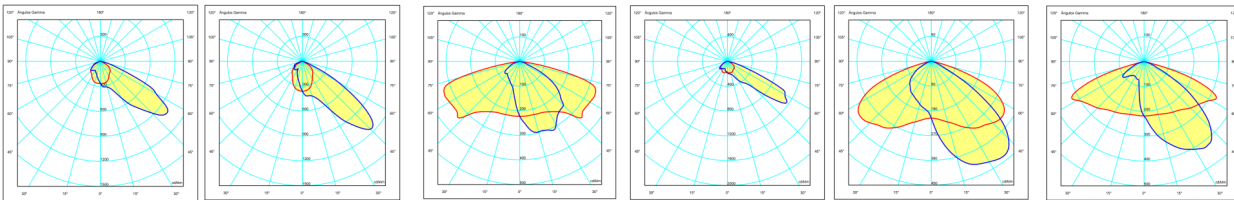

ACA1 ACM1 ALM1 AMA2 AME2 AMM1

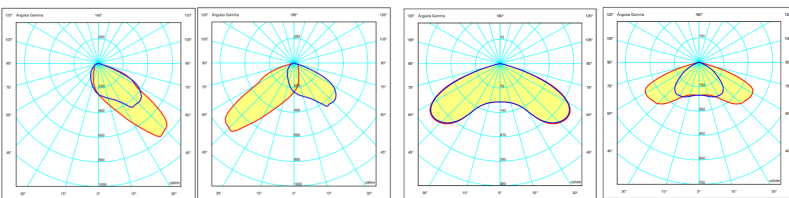

PCE1 PCE2 SMA1 SME1

APPLICATIONS

Greenways and bike lane, train and bus stations, facades and monuments, parks, squares and gardens, residential and pedestrian areas.



Distributor: **EPK elektro s.r.o.**
 info@carandini.cz - www.carandini.cz

SPIN S CHARACTERISTICS

GENERAL INFORMATION

Sustainability	Valorisation: 99,29% Carbon footprint per use: 0,013727 kg kW/h de CO2
CE marking	Yes
ENEC Certificate	Yes
RoHS compliance	Yes
Test standard	LM 79-80 (all measurements in the laboratory certified according to ISO17025)

GENERAL CHARACTERISTICS

Body, Cover and Bracket	Pressure die-cast aluminium EN AC-44100 (LM6) with low copper content <0.1%. Includes a moulded silicone gasket in the perimeter channel.
Entry	M20 nickel plated brass cable gland
Closure	Tempered glass 5mm
Nuts outer and bolts	Stainless steel (AISI304).
Watertightness	IP66 (EN 60598-1 and EN 60529)
Impact protection grade	IK09 (EN 62262)
Operating temperature	Ta -40°C to +50°C According to luminaire configuration.
Lifetime	L90B10 100,000h at Ta of 25°C. Light maintenance assessments to TM-21 based on LM-80 data.

ELECTRICAL CHARACTERISTICS

Electrical class	Class I Class II
Input voltage	220 V - 240 V / 50 Hz - 60 Hz Optional 100 V- 277 V
Power factor	> 0.9 at full load.
Harmonic distortion	< 10%
Overvoltage protection	Overvoltage protection (1.2/50) 10 kV. Maximum current (8/20) 10kA. Maximum voltage (L-N) 320 V. Maximum voltage (L/N-GND) 400 V. Optional overvoltage protection: 20 kA, 20 kV.

LIGHTING CHARACTERISTICS

Package real light	GEN2: 618lm - 7.811lm (6W - 53W) GENA: 762lm - 8.203lm (6W - 53W)
LED color temperature	4,000 K (Neutral White, nw). 3,000 K (Warm White, ww). 2,700 K (Warm White, ww). 2,200 K (Warm White, ww). Amber colour temperature, upon request.
Index of reproduction chromatic (CRI)	CRI>70. CRI80 upon request
LED	Includes 8.16 and 24 LEDs.
F.H.S	Between 0.00% and 0.08% (Upward Light Ratio).
Optics	PMMA polymethylmethacrylate.
Photometric distributions	ACA1: al. Long. 10° ap. trans. 40°/60° (Tipo III) ACM1: al. Long. 15° ap. trans. 45° (Tipo III) ALM1: al. Long. 75° ap. trans. 10°/45° (Tipo III) AMA1: al. Long. 70° ap. trans. 50°/65° (Tipo IV) AMA2: al. Long. 15° ap. trans. 60° (Tipo III) AME2: al. Long. 70° ap. trans. 15°/40° (Tipo II) AMM1: al. Long. 70° ap. trans. 20°/40° (Tipo II) PCE1: al. Long. 50° ap. trans. 45°/55° (Tipo IV) PCE2: al. Long. 50° ap. trans. 50°/60° (Tipo II) SMA1: al. Long. 60° ap. trans. 60° (Tipo VS) SME1: al. Long. 70° ap. trans. 40° (Tipo II)
LED thermal control	Heat dissipation via conduction, radiation and convection based on a design for LED technology.

FINISHES

Predefined luminaire colour

RAL 7015	Gray powder paint RAL 7015 Textured (7015T).
----------	--

Corrosion protection

SEA SIDE SURVIVABLE	Marine Finish (1.000h)
---------------------	------------------------

* For orders of 100 luminaires or more, no price increase will be applied.

*These colours can be painted as long as the pieces allow it.

SPIN S CHARACTERISTICS

MAINTENANCE AND ASSEMBLY

Installation and maintenance	Tool-free luminaire access system designed by Carandini. Access to the driver from the top.
Fixation	<p>BFO: Cast bracket (concealed hose cable outlet). BFS: Cast bracket (upper hose cable outlet). N61: Cast knot 60 (concealed hose cable outlet) PT2: Vertical fixation Ø60mm FMO: Wall fixation (concealed hose cable outlet) FMS: Wall fixation (upper hose cable outlet)</p> <p>N61, PT2, FMO and FMS fixations are supplied with BFO arm. FMS fixation is supplied with BFS arm.</p>
Accessories	<p>BMO: Horizontal steel arm 700mm. PT2-2: Vertical fixation 60 double. N62: Cast knot for Pole 60mm (2 luminaires). KIT-S 12: Lampe transversale 120mm (24-48 LEDs).</p>
Equipped weight	6.7 Kg
Pressure equalisation valve	The luminaire has a pressure equalisation valve to balance internal / external system pressure. Integrating the valve extends the projected lifetime of the gaskets and internal components by reducing the pressure exerted on them, and also prevents the entry of moisture that can cause condensation.
Cables	<p>Classe I/II Câble de 4 à 7 mètres Section transversale : 2x1,5 ; 3x1,5 ; 4x1,5 ; 5x1,5 ; 2x2,5 ; 3x2,5</p>

MANAGEMENT AND CONTROL

Equipment	<p>1N: 1 Level RC: Controller dimmed RD: DALI AF: 1 - 10 V RL: Pulse adjustable LED 2N: 2 Level SR: Smart Ready (D4i)</p>
Autonomous regulation	<p>Regulations programmed from the factory:</p> <p>56: 50% of the 24: 00h at 6: 00h. 66: 60% of the 24: 00h at 6: 00h. 76: 70% of the 24: 00h at 6: 00h. SC: Programming according to client.</p>
CLO regulation	<p>Flow rate during the life of the product:</p> <p>7: 70% luminous flux throughout the life of the luminaire. 8: 80% luminous flux throughout the life of the luminaire. 9: 90% luminous flux throughout the life of the luminaire.</p>
Socket connection	4-X: Zhaga socket with/without IP66 cover
Sensor	2: Photocell for upper ZHAGA base (20 LUX)
Node	BS: Controlux BASIC IMCU

LOGISTICAL INFORMATION

SPIN S

- Box size: 494 x 279 x 200 mm
- Box weight: 6.7 kg.
- Number of boxes: 48 units
- American base: 1200 x 800 x 1670 mm
- Stack height: 8 levels
- Area occupied: 77%
- Volume used: 69%
- Total gross weight: 342 kg.

DIMENSIONS

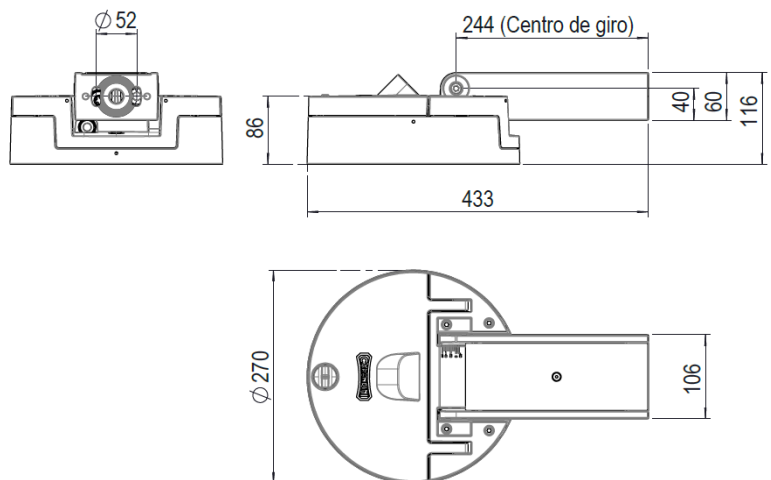
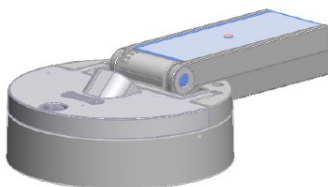

Distributor: EPK elektro s.r.o.
 info@carandini.cz - www.carandini.cz

FIXATIONS

Poles Ø 60 mm

N61 (1 luminaire)

Cast knot 60 (concealed hose cable outlet)
Standard. Code: 380124

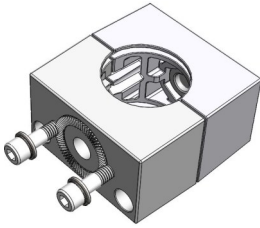

N62 (2 luminaires)

Cast knot for Pole 60mm (concealed hose cable outlet)
Accessories. Code: 380125

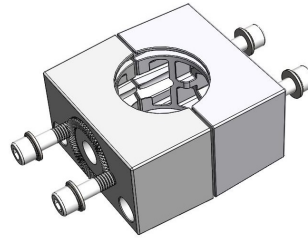

PT2 1 luminaire)

Steel coupling to steel pole the Ø60mmx100mm
(concealed hose cable outlet)
Standard. Code: 320118

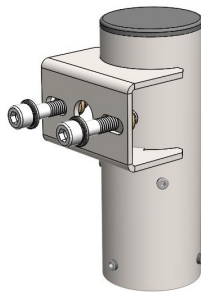

PT2 (2 luminaires)

Steel coupling to steel pole the Ø60mmx100mm
(concealed hose cable outlet)
Accessories. Code: 320141

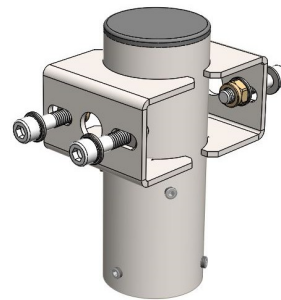

FMO

Steel wall fixation (concealed hose cable outlet)
Standard. Code: 321202

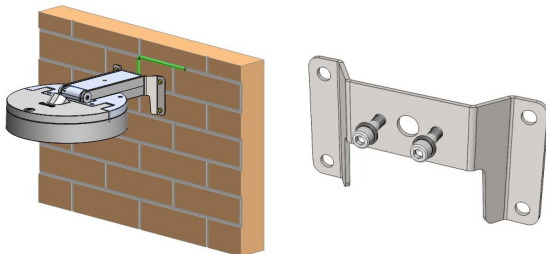

FMS

Steel wall fixation (upper hose cable outlet)
Standard. Code: 380127

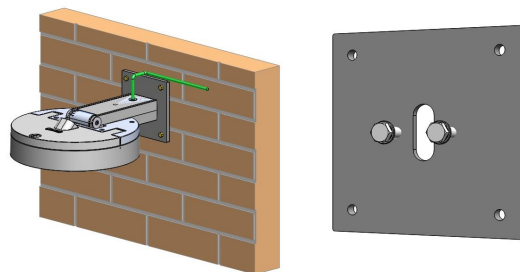

ARMS

BFO (Principal)

Cast bracket (concealed hose cable outlet)
Standard. Code: 380140

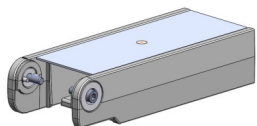

BFS

Cast bracket (upper hose cable outlet)
Standard. Code: 380080

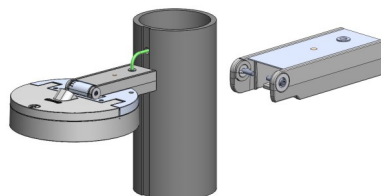

BMO

Steel Arm (concealed hose cable outlet)
Accessories. Code: 320927

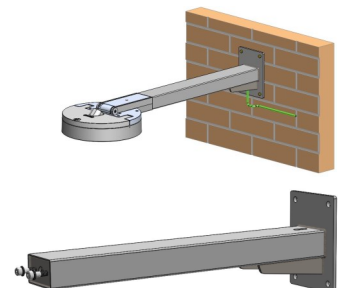

ACCESSORIES

KIT LAMA REAR -12_120mm (KIT-S12)

Accessories. Code: 380179

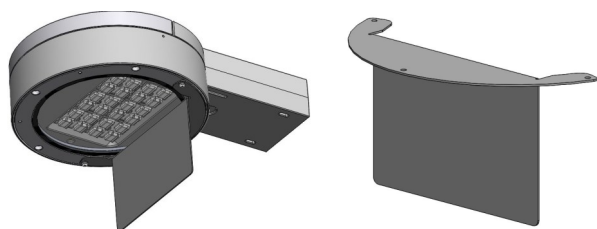

NOTE: Customisable lama according to the project by Carandini.

LUMINAIRE ADJUSTMENT

By programming the driver

Programming profile

The driver can be programmed so that luminous flux is reduced from the luminaire during the least busy hours at night while always meeting the required lighting and uniformity levels.

Programming profile 56

From 00:00 to 06:00 the luminaire reduces its initial intensity by 50%.

Up to

 26% savings

NOTE: Programming the Dynadimmer using the multitone scheduling tool is done for wintertime. In summer everything is delayed by an hour.

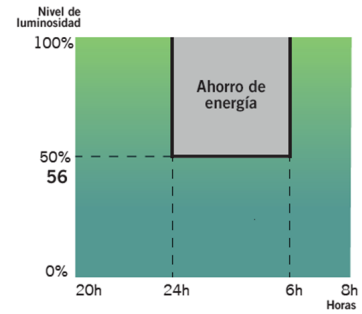

Using the CLO function

Taking into account lighting depreciation over the years, the driver is programmed to start at a reduced level and gradually increase power over the lifetime of the luminaire, which saves energy and increases the service life of the system. In addition, the level of illumination of the area in which it is located is always kept constant.

Constant luminous flux 8

Luminaire luminous flux at 80% to maintain light levels throughout its service life.

Up to

 10% savings
 and increase in luminaire service life

Luminous flux chart

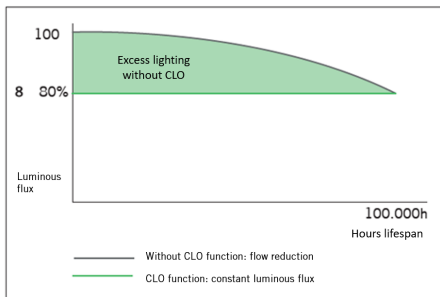

Consumption graph

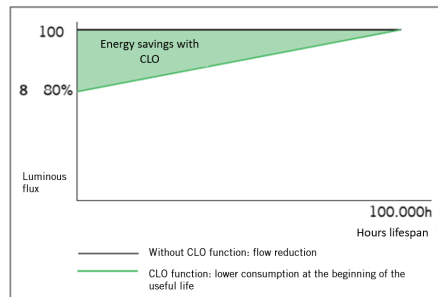

By adding an extra element

Photocell

The photocell allows the luminaire to be switched on or off depending on the intensity of the sunlight it captures.

This is very useful, to avoid having luminaires on at times when there is still enough natural light.

Example with 20 lx photocell:



INNOVATIVE AND UPDATABLE OVER TIME (Zhaga/ ZD4i)

"All luminaires incorporating Nema Bases or Zhaga Bases, where the control system is not the responsibility of Carandini, must always incorporate IP 66 covers in order to ensure the correct safety and operation of the product.

The sale of luminaires with Nema or Zhaga Bases without the IP 66 cover will only be permitted upon receipt of a written assurance from the customer that the control system using NEMA or ZHAGA Nodes will be installed by the customer at the same time as the luminaires".



Zhaga - Future Proof

Zhaga is an industry-wide consortium that aims to standardise specifications for interfaces between LED luminaires and light sources. The aim is to achieve interchangeability between products made by different manufacturers. Zhaga defines test procedures for luminaire and LED light sources so that the luminaire can receive the LED source.



Zhaga D4i - Sensor Ready

The Zhaga consortium joined up with DiiA to create a unique Zhaga-D4i certification that combines Zhaga's Book 18 version 2 outdoor connectivity specifications with Dii4's D4i specifications for intra-luminaire DALI.

BOOKS PER APPLICATION. A COST-EFFECTIVE SOLUTION.



	Office & Industry	Retail & Hospitality	Outdoor
Integrated LED light engines	14, 2,8	17, 16	
LED modules (non-integrated)	7, 21, 14	12, 9, 5, 3,10	4, 15, 19
Drivers	13	LED set 22,23	24,25
Sensor and communication modules		20	18

The specifications that mark a component as Zhaga-compliant are contained in a series of books, available only to consortium members, that allow you to design to the marked standard. The benefits for society are evident since, apart from reducing the consumption of materials, it favours the reuse of luminaires, aiming towards a circular economy.

CERTIFICATION PROGRAMME

Zhaga-D4i certification covers all the essential characteristics, including automatic adjustment, digital communication, data reporting and power requirements in any single luminaire, ensuring plug-and-play interoperability for luminaires (drivers) and peripherals, such as connectivity nodes.

STANDARDISATION AS A MEANS TO ACHIEVE SUSTAINABILITY

The Spin S luminaire has been designed to function with the latest available market-proven technology based on standards. This also enables it to meet the CARANDINI sustainability requirements and become a product ready for maintenance in the future under better guarantees while respecting the environment and society.

The luminaires marked as Zhaga are a "Future Proof" design, meaning it is based on and designed around standard Zhaga components. These components are mainly the LED modules and the drivers. The electric compartment and dissipation area for LED modules has space and additional mountings to include any driver compliant with Zhaga "Book 13" based on market driver dimensions, or any LED module compliant with Zhaga "Book 15" based on LED controller interface specifications.

This makes it possible to have a sustainable product that can be updated over time.

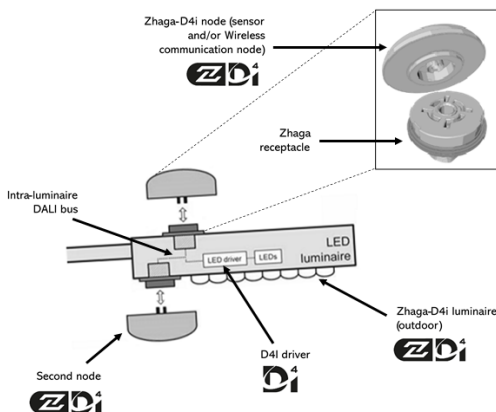

CONNECTIVITY

D4i specifications take the best of the standard DALI2 protocol and adapt it to an interconnected lighting environment, but with certain limitations. Only the control devices installed in the luminaires can be combined with a Zhaga-D4i luminaire. According to the specifications, the control devices are respectively limited to an average power consumption of 2 W and 1 W.

SMART CITY

Luminaires marked ZD4i are a "Smart Ready" design, which means they are designed to house both indoor and outdoor communication nodes through connection sockets compliant with the Zhaga "Book 18" & Zhaga-D4i standard on sensor and communication node interoperability.