

Veka S PP

GEN 2

Pedestrian crossing



KEY BENEFITS

- Up to 5 fixations.
- Tool-free access from the top
- Durability and sturdiness: IP66 + IK08.
- Die Cast aluminium (Cu<0.1%).
- Energy Efficient: GEN2: 169lm /W
- 4 optical distributions specially made for pedestrian crossings
- Smart Ready: Designed to house both indoor and outdoor communication nodes.
- Future Proof: Zhaga-compliant.
- Optional motion sensor that increases the illumination level when a pedestrian is detected.
- Amber or blue flashing lights for greater visibility and driver warning.
- Lifetime L90B10 100.000h (T^a) 25°C.
- Night Friendly: ULR Arrêté du 27/12/ 2018.
- 5 years warranty.

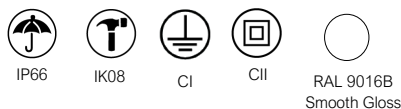

Dark-Sky Association certification
 ≤ 3.000K not available for 4.000K.
 Mechanical adjustment: max. + or- 15
 degrees to allow leveling in the field.



DESCRIPTION

The Veka S PP luminaire integrates seamlessly into the road environment, delivering lighting that effectively captures drivers' attention. It improves pedestrians' horizontal and vertical fields of vision and includes an amber or blue flashing light to warn of the presence of a pedestrian crossing.

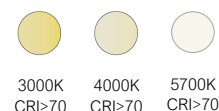

STANDARDS / CERTIFICATES

- CE
- RoHS
- UNE-EN 60598-1
- UNE-EN 60598-2-3
- UNE-EN 62471:2009
- UNE-EN 61000-3-2
- UNE-EN 61000-3-3
- UNE-EN 55015
- UNE-EN 61547
- UNE-EN 62031
- UNE-EN 61347-2-13
- UNE-EN 62384
- UNE-EN 13032-4
- UNE-EN ISO 9227 NSS: 2017 (1,000 h)



2,191 lm - 16,734lm



PT: 0,10536 m²
 SE: 0,11343 m²
 FM: 0,10659 m²
 FT: 0,10759 m²

169lm/W
Luminaire

-40°C - +50°C



5,3 Kg

0,0%
FHS/ULRTool-less
access to
control gear

220 - 240V / 100V - 277V
 50-60Hz
 L90B10 100,000 h
 Ta 25 °C

PHOTOMETRIC DISTRIBUTIONS

4 photometric configurations are available for use in the various environments where this type of luminaire might be installed, meaning it can be adapted to suit all situations:

Ceramic LED:

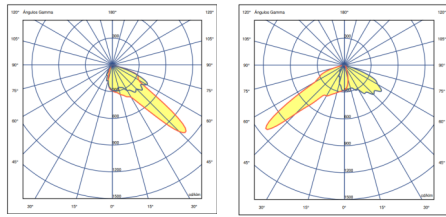

PCE1

PCE2

Polymeric LED:

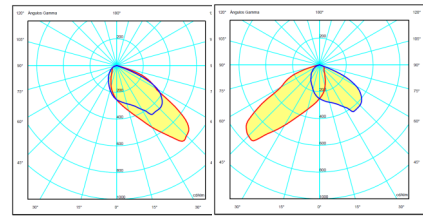

DIMENSIONS

Vertical fixation $\varnothing 76$ mm (PT1)

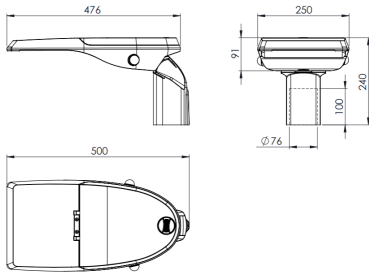

Vertical fixation $\varnothing 76$ mm (PT2)

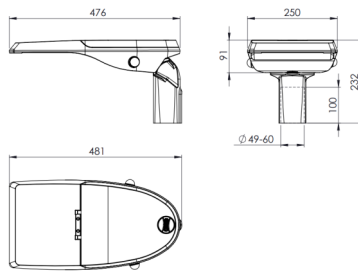

Lateral fixation $\varnothing 34/42$ mm (SE1)

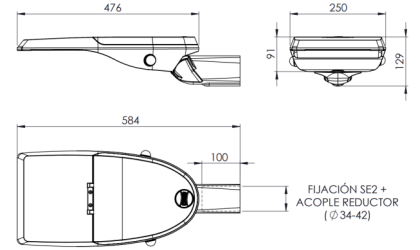

Lateral fixation $\varnothing 49/60$ mm (SE2)

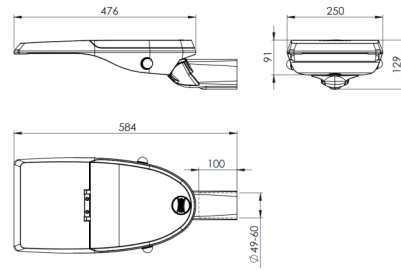

Ceiling fixation (FT1)

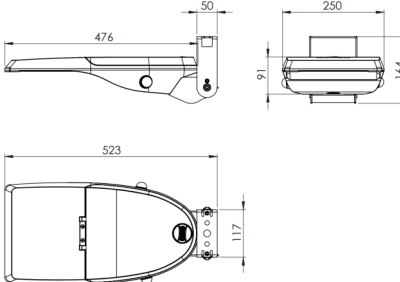

Wall fixation (FM1)

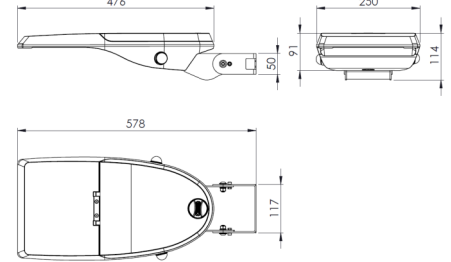

APPLICATIONS

Pedestrian crossings



Distributor EPK elektro s.r.o.
info@carandini.cz - www.carandini.cz

VEKA S PP CHARACTERISTICS

GENERAL INFORMATION

Sustainability	Recyclability: 99,38% Carbon footprint per use: 0,029149Kg kWh de CO2
CE mark	Yes
RoHS-compliant	Yes
Testing standards	LM 79-80 (all measurements at ISO17025 certified laboratory)

GENERAL CHARACTERISTICS

Body and mounting	Die cast aluminum EN AC-44100 (LM6) with low copper content <0.1%.
Closure	Tempered glass 5mm
Nuts outer and bolts	Stainless steel (AISI304).
Watertightness	IP66 (EN 60598-1 and EN 60529)
Impact protection grade	IK08 (EN 62262)
Operating temperature	Ta -40 °C a +50 °C According to luminaire configuration.
Lifetime	L90B10 100,000h at Ta of 25°C. Light maintenance assessments to TM-21 based on LM-80 data.
Cable	Cable from 4 to 10 metres Cross-section: 2x1.5 ; 3x1.5 ; 4x1.5 ; 5x1.5; 2x2.5; 3x2.5

ELECTRICAL CHARACTERISTICS

Electrical class	Class I o Class II
Voltage / Frequency	220V - 240V / 50Hz - 60Hz Optional 100V - 277V
Power factor	> 0,9
Harmonic distortion	< 10%
Protection	Surge protection (1.2 / 50) 10 kV. Maximum current (8/20) 10kA. Maximum voltage (L-N) 320 V. Maximum voltage (L / N-GND) 400 V. Optional overvoltage protection: 20kA, 20kV Disconnecter Cable gland

LIGHTING CHARACTERISTICS

Package real light	GEN2: 2,191 lm to 16,734 lm (16 - 112W) 169lm /W
LED colour temperature	5,700K (Neutral White, nw). 4,000K (Neutral White, nw). 3,000K (Warm White, ww).
Index of reproduction chromatic (CRI)	CRI>70. Optional CRI80.
LEDs	Incorporates 16, 24, 36 and 48 LEDs.
FHS/ULR	0,0%
Optics	PMMA polymethylmethacrylate.
Photometric distributions	PCE1: Throw angle 70° spread angle 65° (Type III) PCE2: Throw angle 65° spread angle 15° (Type II)
LED thermal control	Heat dissipation by conduction through the specific design for this luminaire, since it has been specifically designed for LED technology. (Heatsink).

FINISHES

PREDEFINED COLOUR OF THE LUMINAIRE

RAL 9016	RAL-9016 Traffic white glossy smooth
----------	--------------------------------------

Corrosion protection

	Marine Finish (1.000h) (Optional)
---	-----------------------------------

VEKA S PP CHARACTERISTICS

MAINTENANCE AND ASSEMBLY

Installation and maintenance	Tool-free luminaire access system designed by Carandini. Access to the driver from the top.
Installation	<p>PT1: Vertical fixation \varnothing 76mm.* SE1: Lateral fixation \varnothing 34/42mm. SE2/PT2: Lateral / vertical fixation \varnothing 49/60mm.* FM1: Wall fixation . Includes bracket for direct wall mounting FT1: Ceiling fixation . Includes bracket for direct ceiling mounting</p> <p>*The PT1/PT2 fixations shall be supplied horizontally mounted with SE for sustainability. *The FT1 fixation will be supplied semi-assembled.</p>
Mechanical adjustment	Vertical and lateral fixations offers an angle of inclination range of $\pm 20^\circ$ every 2.5° . The bracket for wall installation offers a range of inclination of $\pm 40^\circ$ every 2.5° .
Equipped weight	<p>PT1: 5,8 kg / PT2: 5,6 kg SE1: 5,3 kg / SE2: 5,6 kg FM1: 5,5 kg FT1: 5,6 kg</p>
Wind Surf.	<p>PT: 0,10536 m² SE: 0,11343 m² FM: 0,10659 m² FT: 0,10759 m²</p>
Pressure equalisation valve	The luminaire is fitted with a valve that compensates any interior pressure to prevent the build-up of condensation, thereby extending the lifespan of the components.
QR label	Optional QR label, with maintenance manual, main luminaire features for troubleshooting and access to the management platform.

MANAGEMENT AND CONTROL

Equipment	<p>1N: 1 Level RD: DALI protocol adjustable (LRD) RL: Dimming a profile adjustable through mains (poulses) SR: Smart Ready D4i</p>
Autonomous regulation	<p>Regulations programmed from factory:</p> <p>56: 50% of the 24: 00h at 6: 00h. 66: 60% of the 24: 00h at 6: 00h. 76: 70% of the 24: 00h at 6: 00h.</p>
CLO regulation	<p>Flow rate during the life of the product:</p> <p>7: 70% luminous flux throughout the life of the luminaire. 8: 80% luminous flux throughout the life of the luminaire. 9: 90% luminous flux throughout the life of the luminaire.</p>
Socket connection	<p>X: ZHAGA top socket 4 pins with IP66 cover Y: ZHAGA socket 4 pin lower with cover IP66 Q: ZHAGA lower and upper socket with cover IP66</p>
Flashing light and sensor	<p>I: Amber flashing light F: Amber flashing light + Zhaga motion sensor J: Blue Flashing light G: Blue Flashing light + Zhaga motion sensor</p>
Node	CD: Citydim

LOGISTICAL INFORMATION

Veka S PP:

Box dimensions: 630 x 300 x 170 mm

Box weight: 6.4 kg

Number of boxes: 32 units

European pallet: 1200 x 800 x 1540 mm

Number of levels: 8 levels

Total gross weight: 225kg

NOTE: By sustainability reasons PT1 fixation accessories will be supplied assembled by side entry (SE)

PHOTOGRAPHS

Veka S PP

No motion sensor

With motion sensor

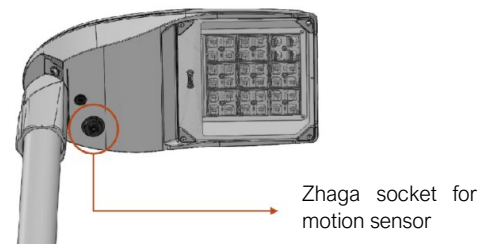
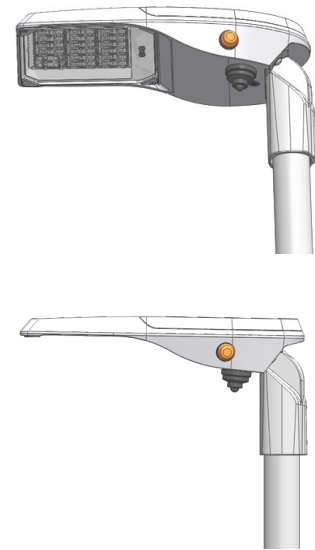
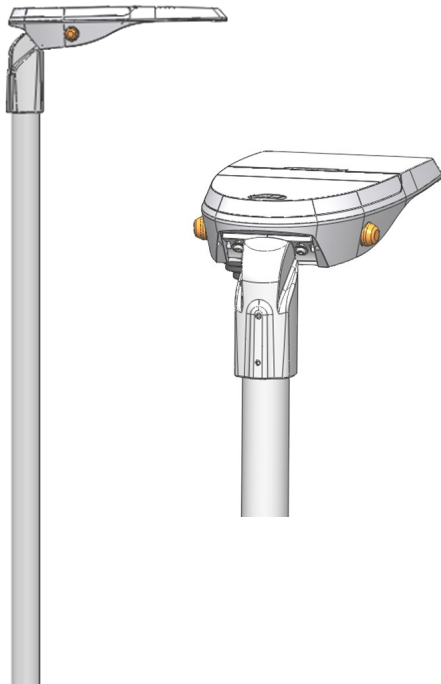

MOTION SENSOR - Ref. 111158

The FDP sensor series allows your fixture to participate in the internet-of-things (IoT) revolution. This sensor family features bi-directional communication between sensor and driver, enabling connected systems for smarter, more energy efficient and data-driven applications. The FDP sensor series is compatible with various intelligent drivers. By connecting to an intelligent driver, the FDP sensor series does not need its own power supply which will save cost and space inside the luminaire.

CHARACTERISTICS

- SR-certified by Philips (FDP-301SR only)*
- 4 pin connector (for Zhaga book 18 socket installation)
- DALI 103 and 303* compatible (FDP-301 only)
- High or low trim fully adjustable from 1 to 10V
- Time delay from 30 seconds to 30 minutes
- Optional cut off delay
- Ramp up and fade down times (2 seconds; 10 seconds)
- Bluetooth Commissioning using the Wattstopper Configuration App
- Polycarbonate construction; flame retardant, UV resistant, impact resistant, recyclable
- UL244A and UL508; IP66 rated (when fully assembled and installed) for use in wet locations
- This product meets the materials restrictions of RoHS.



OPERATION

Typically, the sensor ramps lighting On to the selected High mode level when motion is detected and the ambient light level is below the hold off setpoint. After the sensor stops detecting movement and the time delay elapses, lights fade to the Low mode level. If there is no motion during the subsequent cut off time delay, the lights will turn Off. For dusk to dawn control, the integral photocell can switch the lights On and Off based on the ambient light level so that lighting remains on overnight even without motion detection.

Distributor EPK elektro s.r.o.
info@carandini.cz - www.carandini.cz

LUMINAIRE DIMMING

By programming the driver

Smart luminaires drivers can be programmed in the factory without needing a control system, additional wiring or maintenance costs. A schedule is pre-programmed for light flow to be automatically reduced at quieter times of the night while respecting light levels and uniformity.

Programming profile 56

From 00:00 to 06:00 the luminaire reduces its initial intensity by 50%.

Up to
26%
savings

NOTE: Programming the Dynadimmer using the multitone scheduling tool is done for wintertime. In summer everything is delayed by an hour.

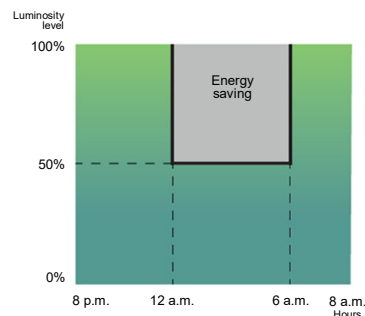

Using the CLO function

Taking into account lighting depreciation over the years, the driver is programmed to start at a reduced level and gradually increase power over the lifetime of the luminaire, which saves energy and increases the service life of the system. In addition, the level of illumination of the area in which it is located is always kept constant.

Constant luminous flux 8

Luminaire luminous flux at 80% to maintain light levels throughout its service life.

Luminous flux chart

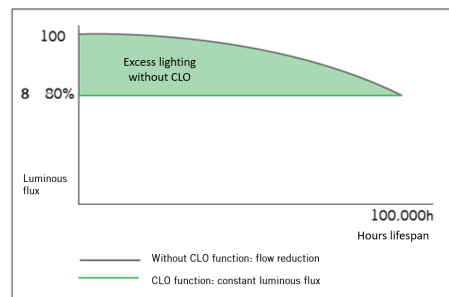

Consumption graph

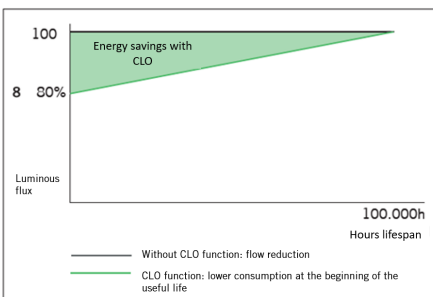

Up to
10%
savings
and increase in luminaire
service life

By adding an extra element

Photocell

The photocell allows the luminaire to be switched on or off depending on the intensity of the sunlight it captures.

This is very useful, to avoid having luminaires on at times when there is still enough natural light.

Example with 20 lx photocell:



INNOVATIVE AND UPDATABLE OVER TIME (Zhaga/ ZD4i)

"All luminaires incorporating Nema Sockets or Zhaga Sockets, where the control system is not the responsibility of Carandini, must always incorporate IP 66 covers in order to ensure the correct safety and operation of the product.

The sale of luminaires with Nema or Zhaga Sockets without the IP 66 cover will only be permitted upon receipt of a written assurance from the customer that the control system using NEMA or ZHAGA Nodes will be installed by the customer at the same time as the luminaires".



Zhaga - Future Proof

Zhaga is an industry-wide consortium that aims to standardise specifications for interfaces between LED luminaires and light sources. The aim is to achieve interchangeability between products made by different manufacturers. Zhaga defines test procedures for luminaire and LED light sources so that the luminaire can receive the LED source.



Zhaga D4i - Sensor Ready

The Zhaga consortium joined up with DiiA to create a unique Zhaga-D4i certification that combines Zhaga's Book 18 version 2 outdoor connectivity specifications with DiiA's D4i specifications for intra-luminaire DALI.

BOOKS PER APPLICATION. A COST-EFFECTIVE SOLUTION.



	Office & Industry	Retail & Hospitality	Outdoor
Integrated LED light engines	14, 2,8	17, 16	
LED modules (non-integrated)	7, 21, 14	12, 9, 5, 3,10	4, 15, 19
Drivers	13	LED set 22,23	24,25
Sensor and communication modules		20	18

The specifications that mark a component as Zhaga-compliant are contained in a series of books, available only to consortium members, that allow you to design to the marked standard. The benefits for society are evident since, apart from reducing the consumption of materials, it favours the reuse of luminaires, aiming towards a circular economy.

CERTIFICATION PROGRAMME

Zhaga-D4i certification covers all the essential characteristics, including automatic adjustment, digital communication, data reporting and power requirements in any single luminaire, ensuring plug-and-play interoperability for luminaires (drivers) and peripherals, such as connectivity nodes.

STANDARDISATION AS A MEANS TO ACHIEVE SUSTAINABILITY

The Veka S PP luminaire has been designed to function with the latest available market-proven technology based on standards. This also enables it to meet the CARANDINI sustainability requirements and become a product ready for maintenance in the future under better guarantees while respecting the environment and society.

The luminaires marked as Zhaga are a "Future Proof" design, meaning it is based on and designed around standard Zhaga components. These components are mainly the LED modules and the drivers. The electric compartment and dissipation area for LED modules has space and additional mountings to include any driver compliant with Zhaga "Book 13" based on market driver dimensions, or any LED module compliant with Zhaga "Book 15" based on LED controller interface specifications.

This makes it possible to have a sustainable product that can be updated over time.

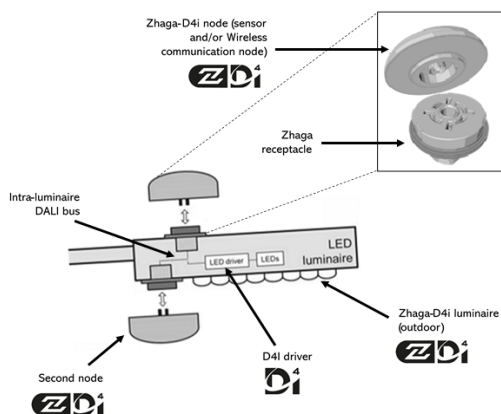

CONNECTIVITY

D4i specifications take the best of the standard DALI2 protocol and adapt it to an interconnected lighting environment, but with certain limitations. Only the control devices installed in the luminaires can be combined with a Zhaga-D4i luminaire. According to the specifications, the control devices are respectively limited to an average power consumption of 2W and 1W.

SMART CITY

Luminaires marked ZD4i are a "Smart Ready" design, which means they are designed to house both indoor and outdoor communication nodes through connection bases compliant with the Zhaga "Book 18" & Zhaga-D4i standard on sensor and communication node interoperability.