

Allgemeine Sicherheitshinweise

General safety notes

- (D)** **(A)** **(CH)** **(FR)**
 - * Montage / Wartung nur durch Fachkräfte.
- Bei Instandsetzung / Instandhaltung nur Originalteile verwenden.
- Werden nachträglich Änderungen an Leuchten vorgenommen, so gilt derjenige als Hersteller, der diese Änderung vornimmt.
- Der Hersteller übernimmt keine Haftung für Schäden, die durch unsachgemäßen Einsatz entstehen.
- (GB)** **(IRL)** **(USA)** **(CAN)** **(AUS)** **(FR)**
 - * Installation / maintenance only by skilled personnel.
 - * During overhaul / maintenance only use original parts.
 - * If any luminaire is subsequently modified, the person responsible for the modification shall be considered the manufacturer.
- The manufacturer bears no liability for damage caused by inappropriate use or application.
- (F)** **(B)** **(CH)** **(CDN)** **(FR)**
 - * Les opérations d'installation et d'entretien doivent être effectuées exclusivement par des personnes qualifiées.
 - * Dans le cas d'une remise en état, utiliser uniquement des composants d'origine.
 - * Toutes modifications apportées au luminaire se feront sous la responsabilité exclusive de celui qui les effectue.
 - * Le fabricant décline toute responsabilité résultant d'un mise en oeuvre inappropriée du produit.
- (E)** **(FR)**
 - * El montaje y mantenimiento lo efectuarán únicamente los técnicos especializados.
 - * Para reparaciones han de emplearse solo piezas originales de recambio.
 - * Reservado el derecho de modificación de dimensiones, pesos y características técnicas, sin previo aviso.
 - * El fabricante no asume responsabilidad por modificaciones realizadas por terceros, ni por instalación incorrecta.
- (I)** **(CH)** **(FR)**
 - * Montaggio / Manutenzione solo per mezzo di Personale specializzati.
 - * Per Riparazione / Manutenzione impiegare solo Parti originali.
 - * Il costruttore si riserva il diritto di apportare senza preavviso modifiche di peso, dimensioni e caratteristiche tecniche.
 - * Il costruttore non è responsabile per danni derivanti da modifiche realizzate da terzi e da una installazione non corretta.
- (P)** **(FR)**
 - * Montagem /Manutenção efectuada unicamente por pessoal técnico especializado.
 - * Utilizar somente peças originais do fabricante.
 - * O fabricante não se responsabiliza por danos resultantes da inadequada utilização dos materiais.
- (H)** **(FR)**
 - * A szerelést / karbantartást csak szakszemélyzet végezheti.
 - * Üzembehelyezéssel / karbantartással csak eredeti alkatrészeket használhatók.
- (GR)** **(FR)**
 - * Τοποθέτηση / Σιμωτήριση μόνο από ηλεκτρολόγο
 - * Κατά την επισκευή / διατήρηση χρησιμοποιείτε γνήσια ανταλλάκτικά μόνο
- (NL)** **(FR)**
 - * Montage / service alleen door vakkundig personeel.
 - * Bij inbedrijfstellen / onderhoud allen originele onderdelen gebruiken.
- (N)** **(FR)**
 - * Monteres kun av fagpersonell.
 - * Ved feilretting : Bruk kun originaldelar.
- (S)** **(FR)**
 - * Monterings åtgärser endast av fackfolk.
 - * Använd bara originaldelar vid igångsättning / underhåll.
- (R)** **(FR)**
 - * При ремонте применять только новые части.
 - * Монтаж / обслуживание только оригинальными.
- (CZ)** **(SK)** **(FR)**
 - * Montáž a údržba může být prováděna výhradně odbornou pracovní sílou.
 - * Při údržbě nebo opravě musí být použitý jen originální náhradní díly.
- (TR)** **(FR)**
 - * Montaj ve Bakım sadece yetkili personel tarafından yapılmalı dir.
 - * Bakımda sadece orijinal parçalar kullanılmalıdır.
- (POL)** **(FR)**
 - * Montaż / konserwacja tylko przez fachowy personel.
 - * Dla naprawy / bieżącej eksploatacji stosować tylko oryginalne części zamienne.
- (SLO)** **(FR)**
 - * Montažo vzdrževanje lahko izveši le ustrezno usposobljena oseba.
 - * Pri popravilu/vzdrževalnih delih se lahko uporabljajo samo originalni deli.
 - * V kolikor se na svetilkah naknadno izvedejo spremembe, se za proizvajalca svetilke smatra tisti, ki je izvedel spremembo.
 - * Proizvajalec ne jamci za škodo, ki bi nastala zaradi nepravilne uporabe.
- (HRV)** **(BH)** **(FR)**
 - * Montažu održavanje mora izvrši odgovarajuće osposobljena osoba.
 - * Pri popravku/održavanju koristiti samo originalne dijelove.
 - * Ukoliko se na svjetiljkama naknadno vrše promjene, za proizvođača svjetiljke se smatra taj koji je promjene izvršio.
 - * Proizvođač ne garantuje za štetu koja bi mogla nastati usled nepravilne upotrebe.
- (SCG)** **(FR)**
 - * Montažu/održavanje može da obavi samo stručno osposobljena osoba.
 - * Pri popravljaju/održavanju upotrebljavati samo originalne delove.
 - * Ukoliko se na svjetiljkama naknadno vrše promjene, za proizvođača svjetiljke se smatra taj koji je promjene izvršio.
 - * Proizvođač ne garantuje za štetu koja bi mogla nastati usled nepravilne upotrebe.

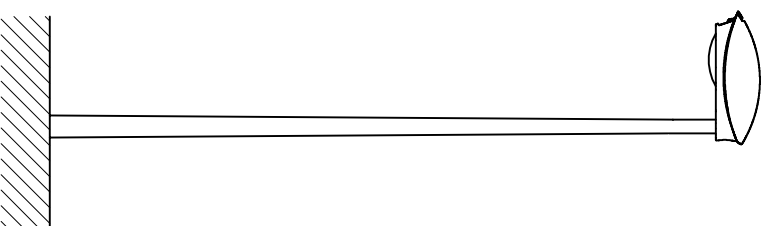

siteco

Siteco Beleuchtungstechnik,
Olmstraße 50, 83301 Traunreut
Anrufen: 0 86 69/33-822
Faxen: 0 86 69/33-540
E-Mail: info@siteco.de
Internet: www.siteco.de

Wenn Sie technische Fragen haben:
Hotline: 08669 / 33-844

Siteco Lighting Systems,
Olmstraße 50, D-83301 Traunreut
Phone: +49 8669/33-822
Fax: +49 8669/33-540
mail: info@siteco.de
Surf: www.siteco.de

If you have technical questions:
Hotline: +49 8669 / 33-844

Montage- /
Betriebsanleitung
Mounting- /
Operating instruction

Aussenleuchte
exterior luminaire
SQ 50

5NA557
5UK557

Bestellnr./Order-number: 4MA72-117708ae

copyright Siteco
Änderungen vorbehalten
Datum:ad / 11.2006

Bitte aufbewahren!
Please keep for future reference!

**5NA557.-.....
5UK557.-.....**

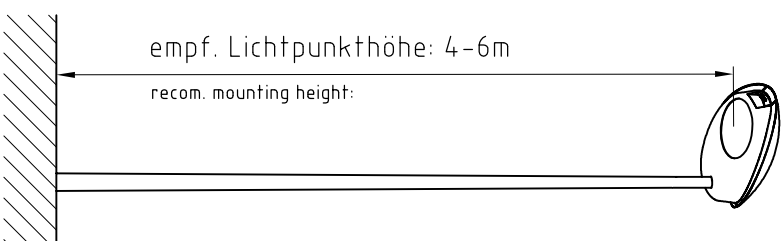
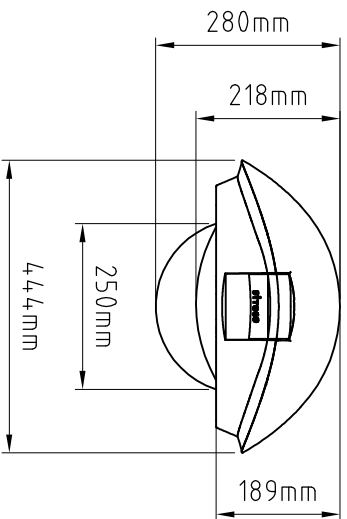
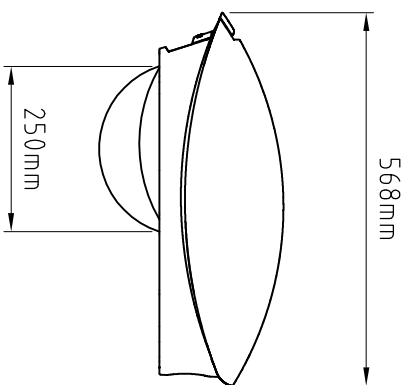

	$A_w = 0,101\text{m}^2$
	$A_w = 0,095\text{m}^2$
	$A_w = 0,084\text{m}^2$

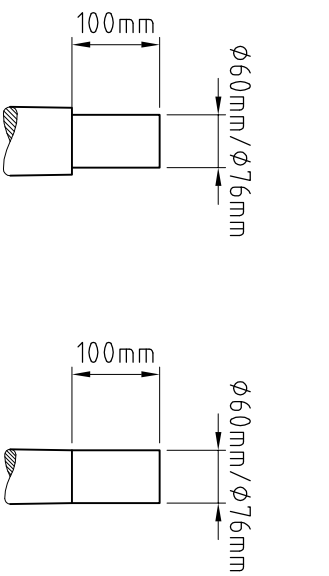
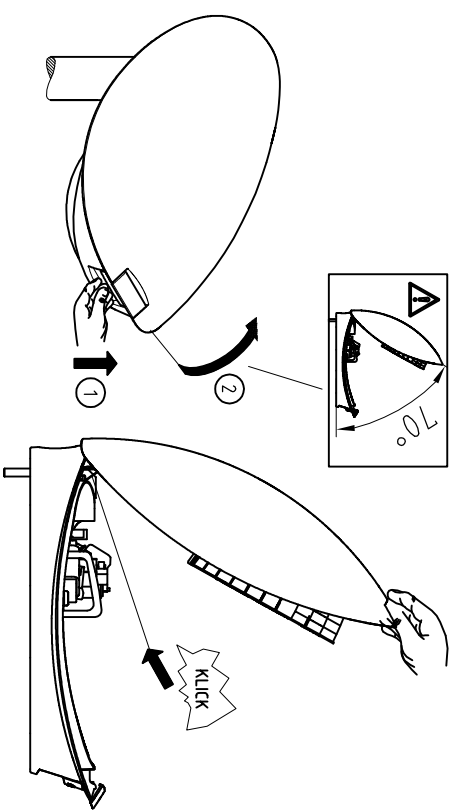

h	V _{max}
φ60-φ76 <15m	188
φ76 >15m	205

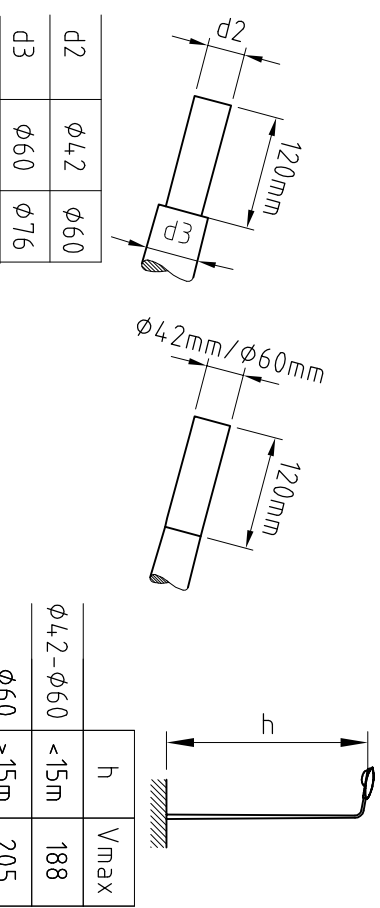

h	V _{max}
φ42-φ60 <15m	188
φ60 >15m	205

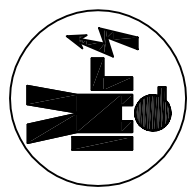

Sz3 T20

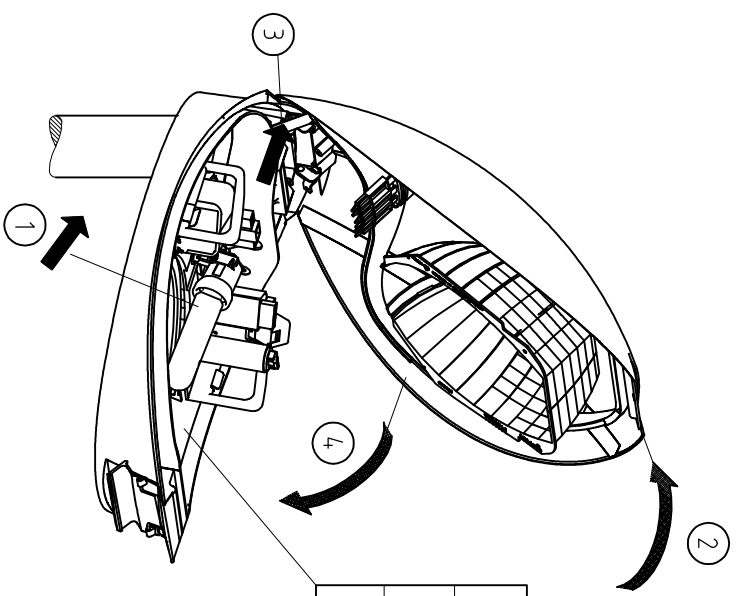
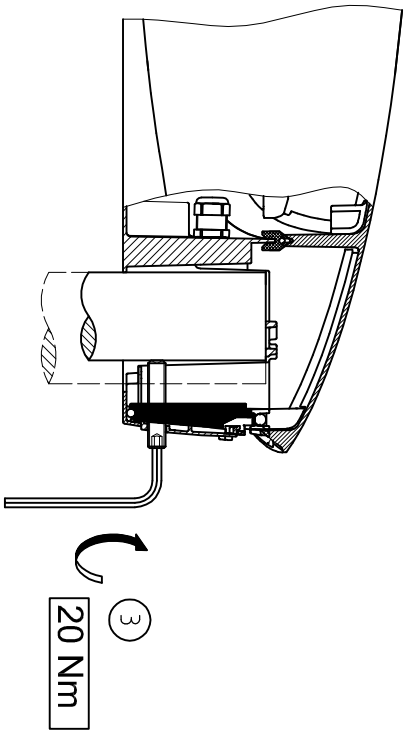
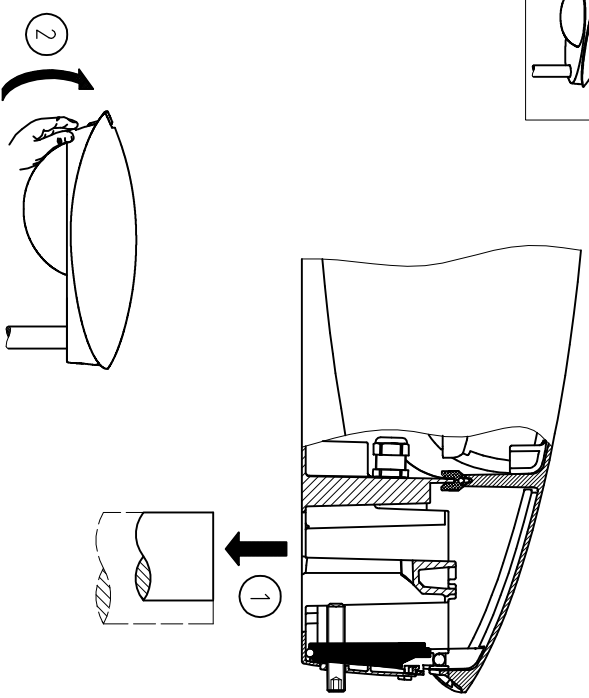
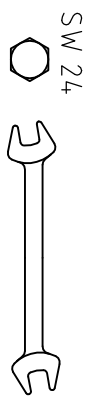
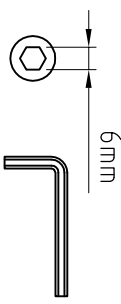

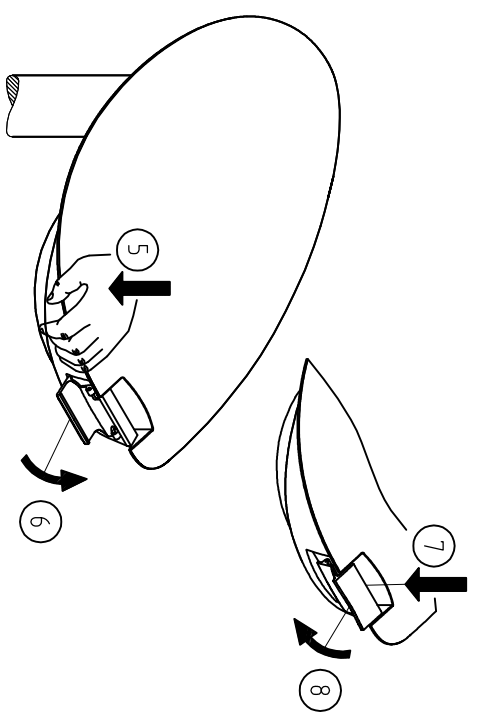

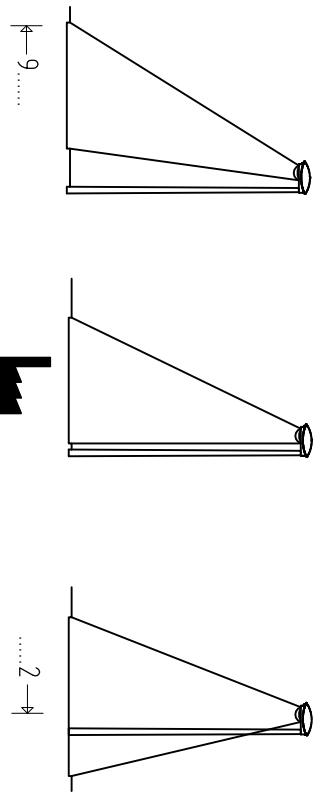

x=2mm ± 1°

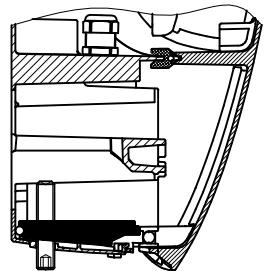
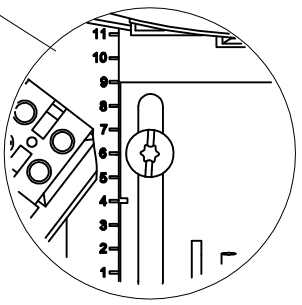
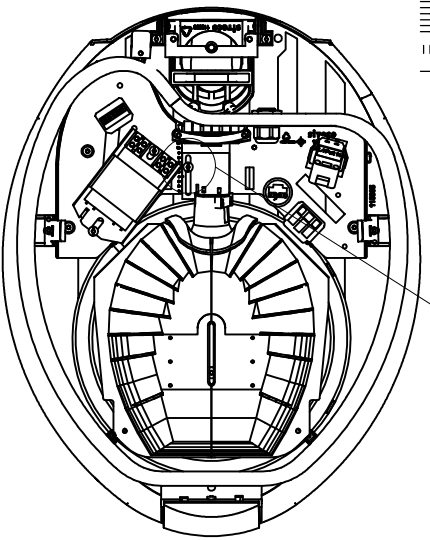

1

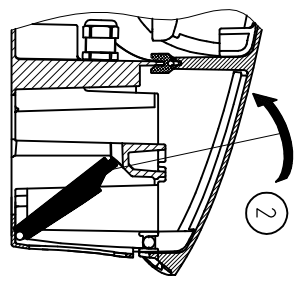

2

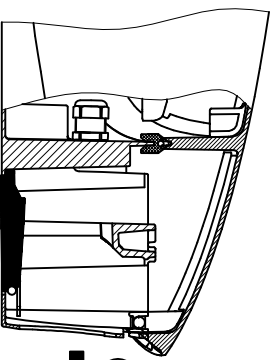

3



4



5

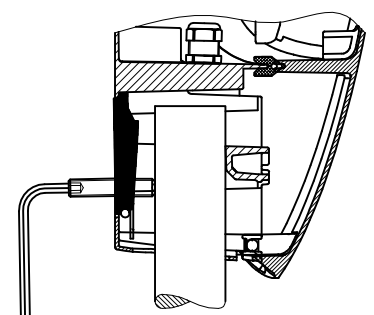

20 Nm

6

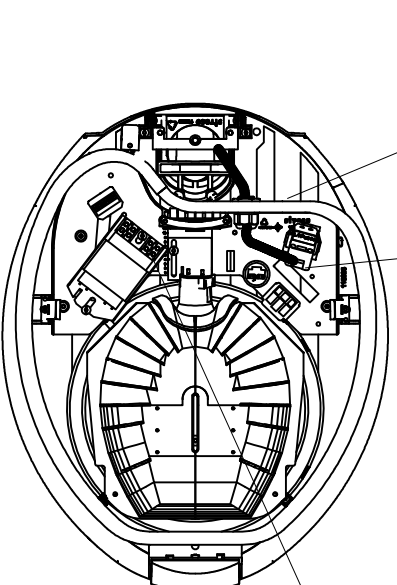
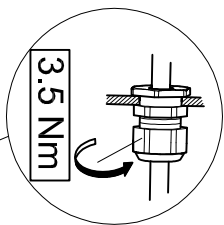
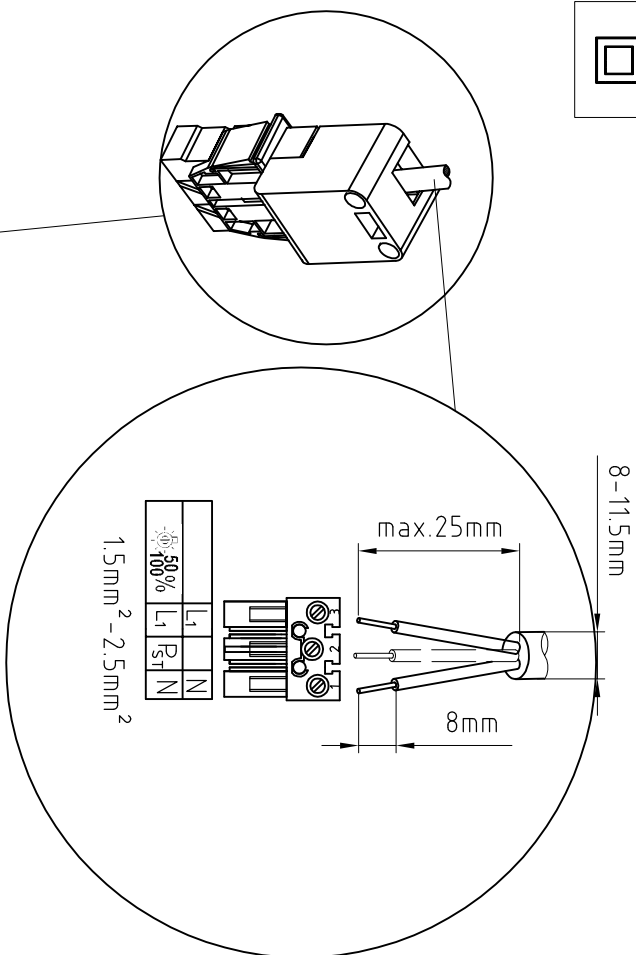
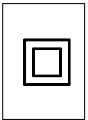

HM	80W	230V
	125W	230V
HS	50W	230V
	70W	230V
	100W	230V

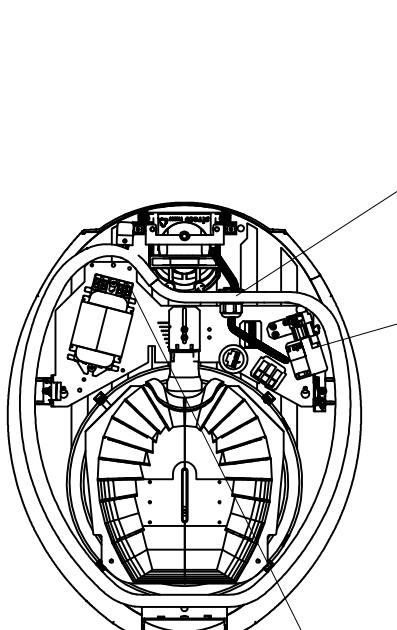
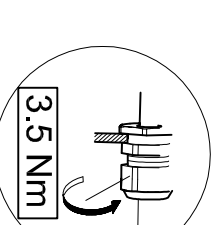
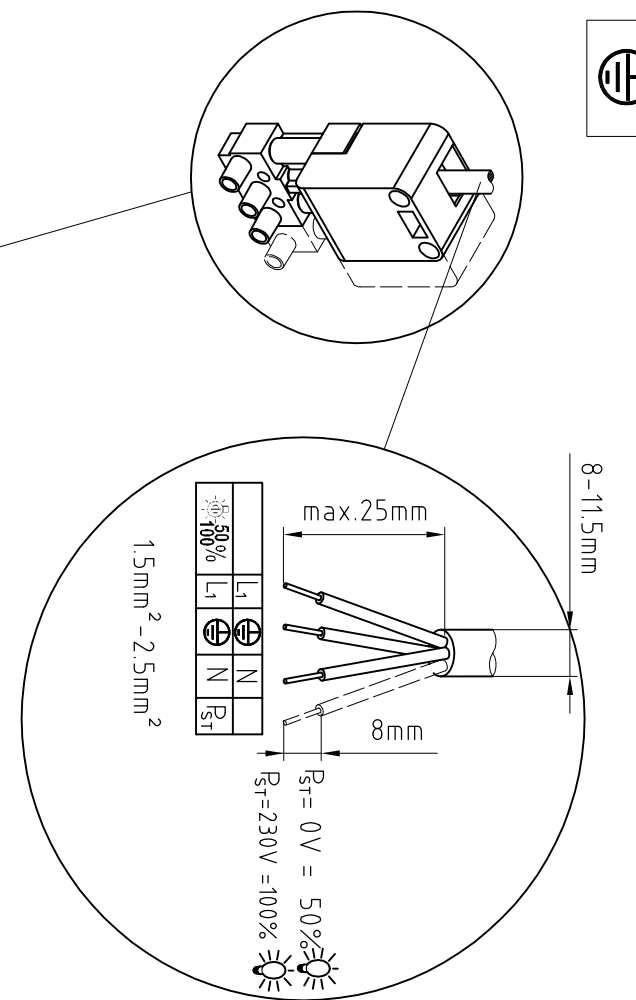

HM	80W	230V
	125W	230V
HS	50W	230V
	70W	230V
	100W	230V

